



Vacuum Spotting Board

Model A

OWNER'S MANUAL

CISSELL MANUFACTURING COMPANY
HEADQUARTERS
831 SOUTH FIRST ST.
P.O. BOX 32270
LOUISVILLE, KY 40232-2270

PHONE: (502) 587-1292
SALES FAX: (502) 585-3625
SERVICE/PARTS FAX: (502) 681-1275

THIS MANUAL MUST BE GIVEN TO THE EQUIPMENT OWNER.

MAN61 (ECN5680) 10/99 WB 2C

WARRANTY

The Cissell Manufacturing Company (Cissell) warrants all new equipment (and the original parts thereof) to be free from defects in material or workmanship for a period of one (1) year from the date of sale thereof to an original purchaser for use, except as hereinafter provided. With respect to non-durable parts normally requiring replacement in less than one (1) year due to normal wear and tear, including, but not limited to, cloth goods, valve discs, hoses, and iron cords, and with respect to all new repair or replacement parts for Cissell equipment for which the one (1) year warranty period has expired, or for all new repair or replacement parts for equipment other than Cissell equipment, the warranty period is limited to ninety (90) days from date of sale. The warranty period on each new replacement part furnished by Cissell in fulfillment of the warranty on new equipment or parts shall be for the unexpired portion of the original warranty period on the part replaced.

With respect to electric motors, coin meters and other accessories furnished with the new equipment, but not manufactured by Cissell, the warranty is limited to that provided by the respective manufacturer.

Cissell's total liability arising out of the manufacture and sale of new equipment and parts, whether under the warranty or caused by Cissell's negligence or otherwise, shall be limited to Cissell repairing or replacing, at its option, any defective equipment or part returned f.o.b. Cissell's factory, transportation prepaid, within the applicable warranty period and found by Cissell to have been defective, and in no event shall Cissell be liable for damages of any kind, whether for any injury to persons or property or for any special or consequential damages. The liability of Cissell does not include furnishing (or paying for) any labor such as that required to service, remove or install; to diagnose troubles; to adjust, remove or replace defective equipment or a part; nor does it include any responsibility for transportation expense which is involved therein.

The warranty of Cissell is contingent upon installation and use of its equipment under normal operating conditions. The warranty is void on equipment or parts; that have been subjected to misuse, accident, or negligent damage; operated under loads, pressures, speeds, electrical connections, plumbing, or conditions other than those specified by Cissell; operated or repaired with other than genuine Cissell replacement parts; damaged by fire, flood, vandalism, or such other causes beyond the control of Cissell; altered or repaired in any way that effects the reliability or detracts from its performance, or; which have had the identification plate, or serial number, altered, defaced, or removed.

No defective equipment or part may be returned to Cissell for repair or replacement without prior written authorization from Cissell. Charges for unauthorized repairs will not be accepted or paid by Cissell.

CISSELL MAKES NO OTHER EXPRESSED OR IMPLIED WARRANTY, STATUTORY OR OTHERWISE, CONCERNING THE EQUIPMENT OR PARTS INCLUDING, WITHOUT LIMITATION, A WARRANTY OF FITNESS FOR A PARTICULAR PURPOSE, OR A WARRANTY OF MERCHANTABILITY. THE WARRANTIES GIVEN ABOVE ARE EXPRESSLY IN LIEU OF ALL OTHER WARRANTIES, EXPRESSED OR IMPLIED. CISSELL NEITHER ASSUMES, NOR AUTHORIZES ANY PERSON TO ASSUME FOR IT, ANY OTHER WARRANTY OR LIABILITY IN CONNECTION WITH THE MANUFACTURE, USE OR SALE OF ITS EQUIPMENT OR PARTS.

For warranty service, contact the distributor from whom the Cissell equipment or part was purchased. If the distributor cannot be reached, contact Cissell.

TABLE OF CONTENTS

Warranty	2
Table of Contents	3
Dimension Drawings	4
Installation Illustration	5
Specifications	6
Installation of Steam Lines	6
Mechanical Operation	7
Mechanical Maintenance	7
Operating Instructions	8
Adjustment of Wet and Dry Steam Valves	9
 <u>Illustrated Parts</u>	
Overall View	10-11
Large Board	12
Swinging Sleeve Board	13
Spotting Gun and Hose	14
Chemical Tray	15
Steam Chamber and Valve Assembly	16-17
Base Assembly	18
Central Air Vacuum	19
Steam Vacuum	20
Head Valves & Service Instructions	21
 Trouble Shooting Chart	 22

VACUUM SPOTTING BOARD MODEL 'A' GENERAL SPECIFICATIONS

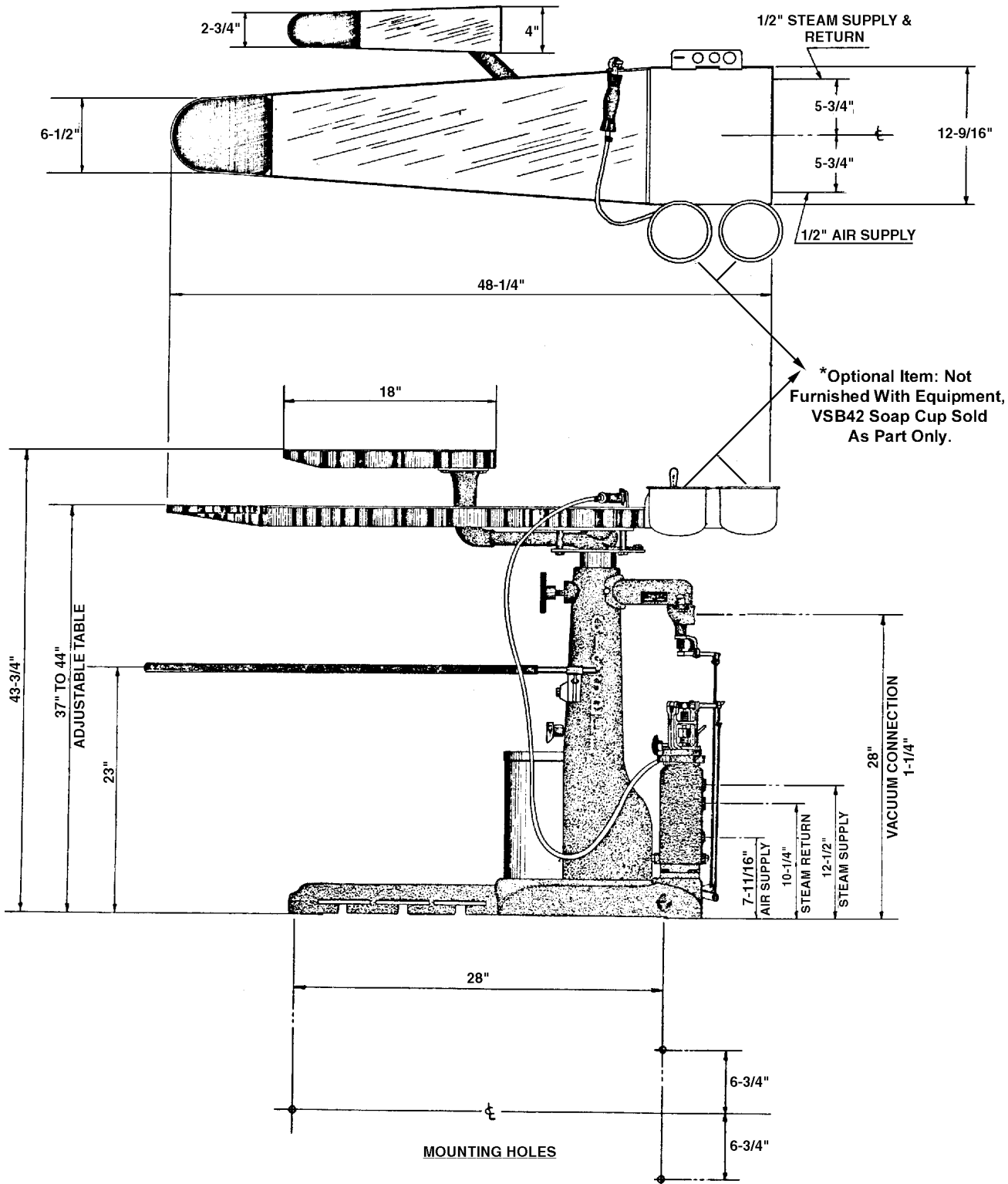

**VACUUM SPOTTING BOARD
MODEL 'A'
INSTALLATION ILLUSTRATION**

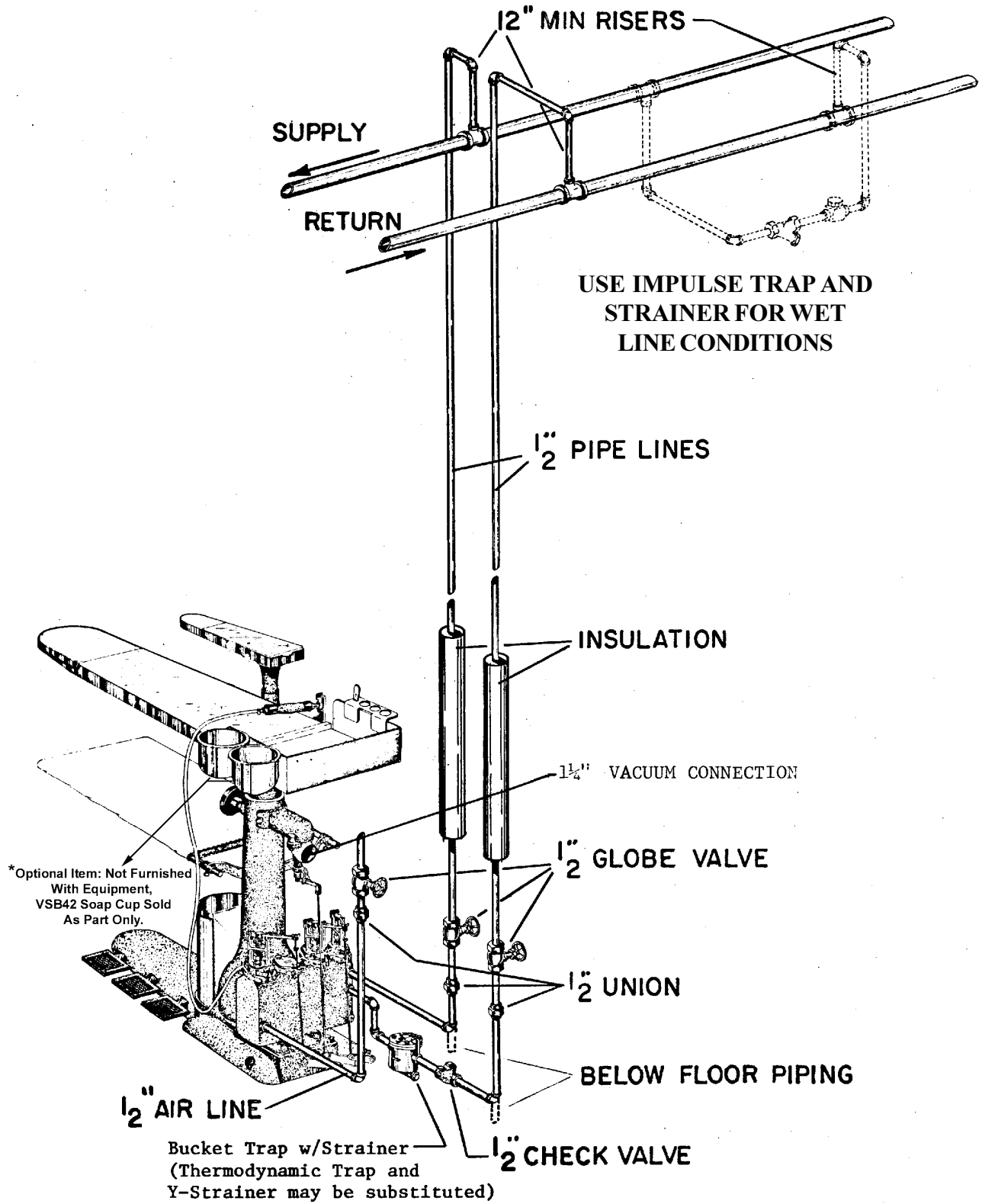

SPECIFICATIONS - VACUUM SPOTTING BOARD

Net Weight	235 lb (107 kg)
Domestic Shipping Weight (1 Carton)	280 lb (127 kg)
Export Shipping Weight (1 Box)	435 lb (197 kg)
Export Shipping Dimensions	47" (1194 mm) H, x 53" (1346 mm) L, x 20" (508 mm) W
Export Crate Volume	29 Cu. Ft. (0.821 m ³)
Floor Space	20" (508 mm) x 48" (1219 mm)
Table Height (Adjustable)	37" (940 mm) to 44" (1118 mm)
Length of Working Surface	38" (965 mm)
Width at Front End of Large Board	6 1/2" (165 mm)
Width at Rear End of Large Board	12 1/2" (318 mm)
Width at Front End of Swinging Sleeve Board	2 1/2" (64 mm)
Width at Rear End of Swinging Sleeve Board	4" (102 mm)
Boiler Horsepower (approximate)	1 1/4
Operating Steam Pressure	100 psi max. (6.9 Bars)
Steam Supply Connection	1/2" Pipe (DN15)
Steam Return Connection	1/2" Pipe (DN15)
Vacuum Outlet Connection	1 1/4" Pipe (DN32)
Vacuum Requirement	1 Press capacity (1/2 Hp.)

NOTE: An air compressor is required for the heated compressed air feature. A 1 hp. (746W) compressor delivering 6 (2.8 I/s) to 8 (3.8 I/s) cfm at 80 (356N) to 125 (556N) lbs. pressure will accommodate one board; a 1 1/2 hp. (1119W) compressor will accommodate two boards.

INSTALLATION OF STEAM LINES

Steam supply line must fall towards machine (without water pockets.) Connect spotting board to steam supply line with union, globe valve and 12" (or more) riser, as illustrated on previous page. If spotting board is located at the end of steam line, extend line at least 4 feet beyond machine, and install a by-pass trap and check valve as illustrated in dotted lines; if gravity return, omit trap.

Steam return line must fall towards boiler (without water pockets). Connect spotting board to steam return line with a swing connection, unions, strainer, trap, check valve and 12" (or more) riser as illustrated on reverse side. Inspect trap carefully for inlet and outlet markings and install swing connection, trap, and check valve as close to machine as possible with trap as close to floor as practical.

Use a separate trap for the spotting board; keep it clean and in good working condition for best performance. If steam line is gravity returned to boiler, omit trap.

IMPORTANT: Before installing trap and connecting steam return line, open globe valve in steam supply connection and flush pipe dope, borings and other foreign matter, from steam connections and steam chamber within spotting board. Failure to do this may later cause trap trouble.

VACUUM SPOTTING BOARD

VACUUM SPOTTING BOARD MECHANICAL OPERATION

Vacuum draws uniformly through the screen area on the nose of the board and the nose of the swinging sleeve board by pressing on the middle foot pedal. By pushing the swinging sleeve board back, the vacuum operates on the nose of the large board. By pulling the swinging sleeve board forward, vacuum operates on its nose. Changing the position of the swinging sleeve board operates a self-cleaning valve which gives full unrestricted passage for vacuum at all times.

Steam is released from the spotting gun by pressing the left foot pedal as follows: a slight touch releases a feather of dry steam; partly down releases dry steam; half-way down releases moist steam; completely down releases wet steam.

CAUTION: The steam emitted from the spray gun is very hot. Burns to face and hands may result from contact with live steam.

Hot air for drying is released from the spotting gun by pressing the right foot pedal.

Automatic check valve releases all chemicals and water from vacuum chamber to an extra large drain receptacle. No pipe line or sewage connection is needed.

Adjustable board for operator comfort from 37" to 44" in height. Loosen knob near top of the column, slide top assembly up or down to desired height, then tighten knob.

MECHANICAL MAINTENANCE

CLEANING LARGE PAN ASSEMBLY

Lift chemical tray and large vitrelite glass from board.

Tap off nose band and perforated metal, clean with steam gun.

Clean pan of all dirt, lint and chemicals.

Open drain holes with a hairpin or pointed instrument. It is important that these drain holes are open in order that the vacuum can extract any liquids that form in the pan.

CLEANING SWINGING ARM ASSEMBLY

Lift out small green vitrelite glass by finger hole at back of pan.

Remove perforated metal.

Clean with steam gun.

Clean pan or all dirt, lint and chemicals (use steam gun).

Open drain holes (in pan) with a hairpin or pointed instrument.

VACUUM SEAL

The rubber air-foam gasket around pipe of top assembly at top of column is a seal to help create a stronger vacuum. Should this gasket become loose, re-cement into position.

CHECK VALVE

Inspect and clean check valve located above drain receptacle. Liquids separated from the vacuum exhaust within the column are automatically drained from board by check valve.

Lift drain receptacle up and out for emptying.

UPPER AND LOWER SLIDE

A few drops of oil on the upper and lower slides of the swinging arm assembly will permit easier operation.

SPOTTING BOARD OPERATING INSTRUCTIONS

FOR REMOVING SPOTS

Place garment in position over screened area of board so that spot is directly over the vacuum ring area. On tight-fitting sleeves, cuffs, neckties, etc. when it is impossible to use the large board, use the swinging sleeve board by swinging it forward and use it as you would the larger board.

1. With garment in position, using one foot, press both the vacuum (left) and steam (center) foot pedals all the way down. The vacuum will hold the garment in place.

CAUTION: Be sure to have the spotting gun pointed away from your face or body as live steam is very hot and may cause burns.

2. Place gun in position approximately two inches above material.

3. Now, with gun in rotary motion (heavy arrows), spray wet steam downward straight through spotted area. Ample wet steam under pressure dissolves water-soluble spots instantly. Concentrated vacuum keeps wetted area from spreading as it draws the wet steam through the garments (light arrows).

FOR DRYING

4. With one foot, press both vacuum pedal and air pedal all the way down and clear moisture from gun before starting to dry.

5. Hold gun only the width of gun nozzle above garment.

6. Now, move gun in a zig-zag motion sweeping it rapidly back and forth across wetted area for drying (heavy arrows). Actually, excess moisture blown out with compressed air, and wetted area dried rapidly with the strong suction from the concentrated vacuum.

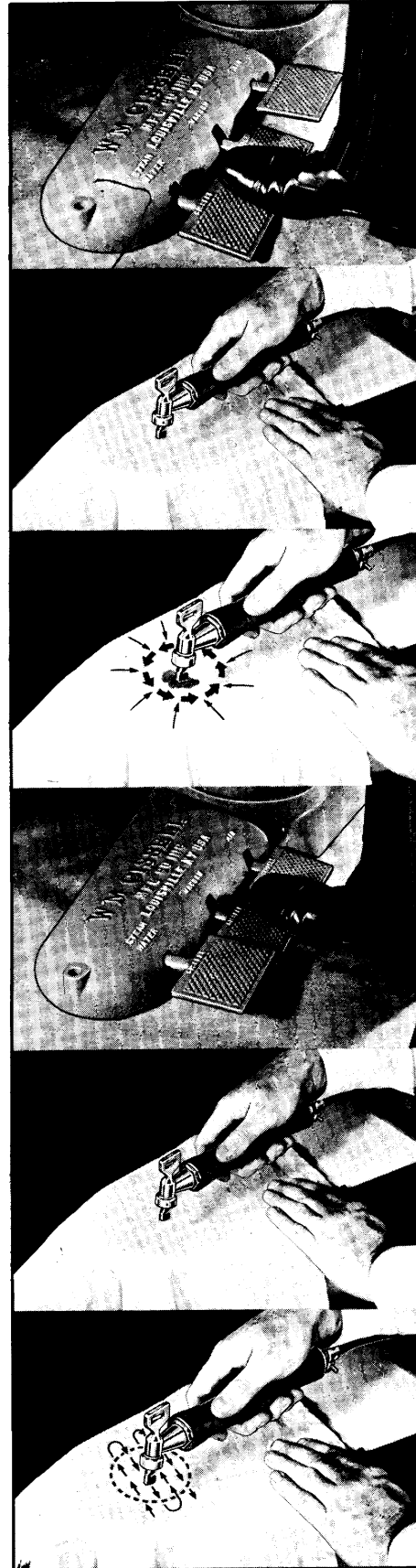

INSTRUCTIONS FOR ADJUSTING WET AND DRY STEAM VALVES

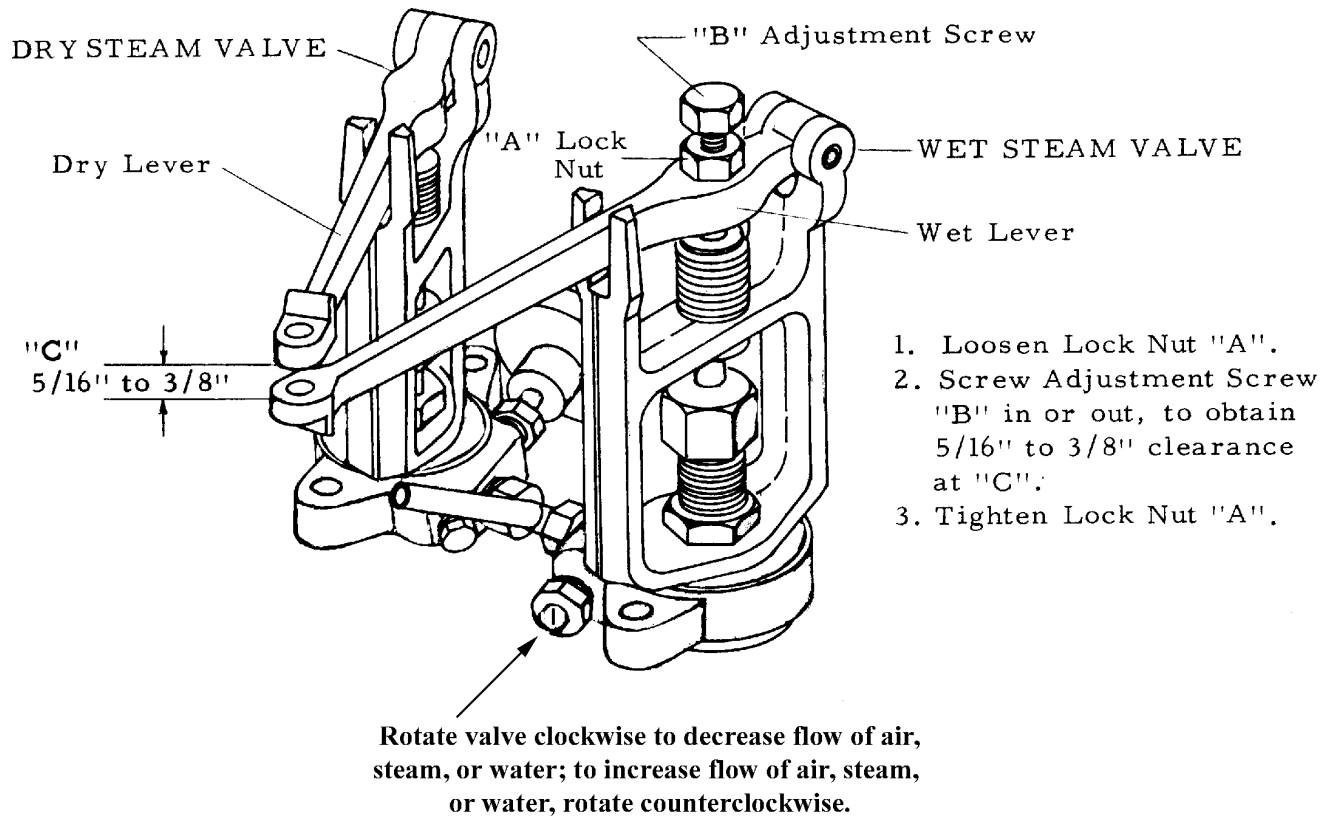

VACUUM SPOTTING BOARD MODEL 'A' PARTS & ASSEMBLY

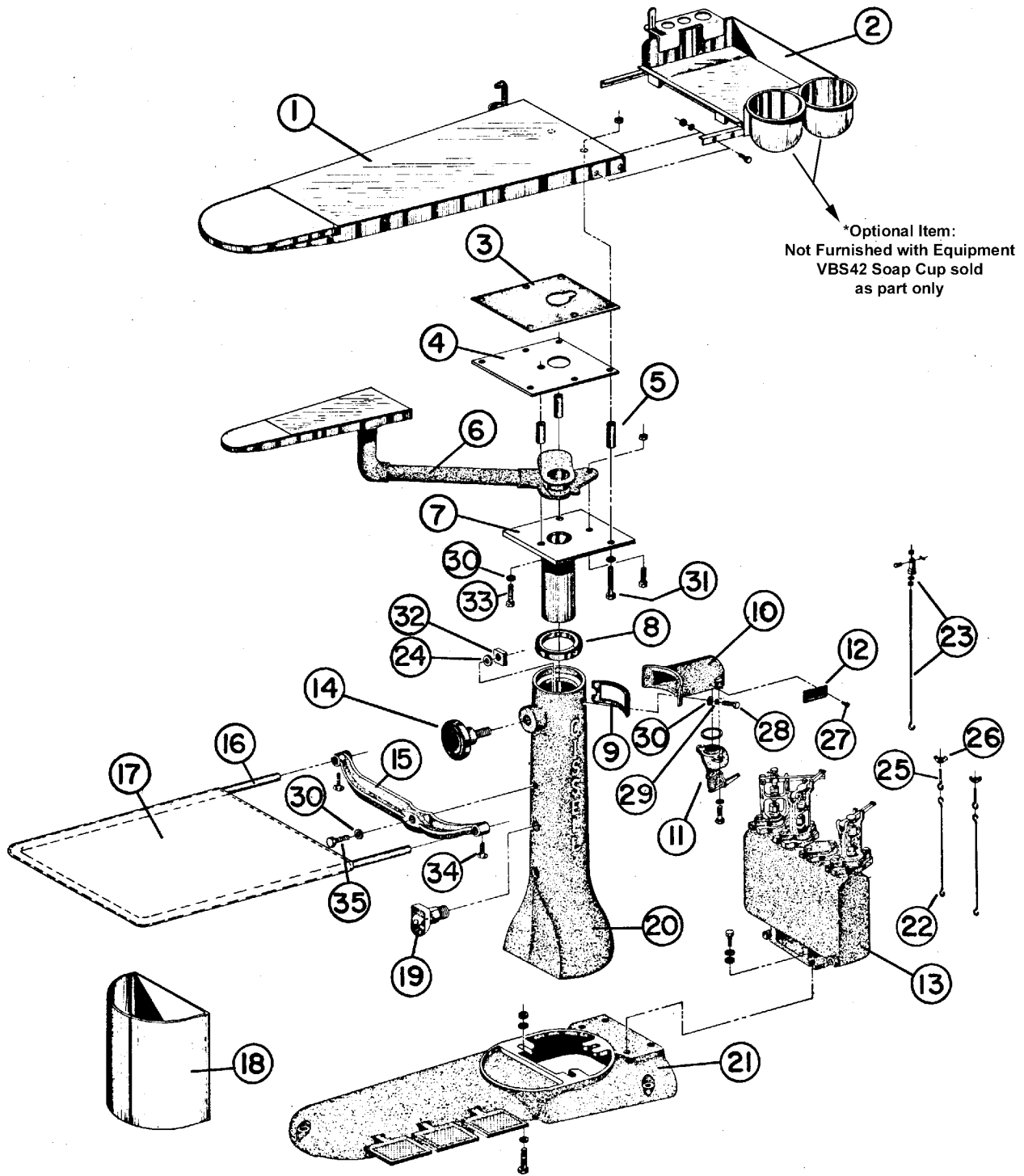

<u>Ref. No.</u>	<u>Part No.</u>	<u>Description</u>
1	----	See Page 11
2	----	See Page 14
3	VSB20	Gasket
4	VSB9	Upper Stainless Plate
5	VSB18	Spacer (3 req'd)
6	----	See Page 12
7	VSB109	Pipe & Lower Plate
8	VSB47	Rubber Seal
9	VSB16	Gasket
10	VSB5	Vacuum Chamber Casting
11	----	See Page 19
12	F1116	Ser. No. Tag
13	----	See Pages 15-16
14	SF22	Knob
15	VSB158	Tray Bucket w/ Thumb Screws
16	VSB105	Tray Rod
17	SF28	Tray Cover
18	VSB59P	Drain Receptacle
19	VSB48	Check Valve Assembly
20	VSB2	Column
21	----	See Page 17
22	VSB31	16" Pedal Rod
23	----	See Page 18
24	VSB170	Rubber Gasket
25	J10	3/16 x 3 Eye Bolt
26	VSB154	#10-24 Wing Nut
27	M263	#8-3/8" Sheet Metal Screw
28	FB124	5/16 Hex. Hd. Cap Screw
29	TU2814	5/16 Lock Washer
30	VSB130	5/16 Cut Washer
31	VSB87	5/16 - 8 x 3" Bolts
32	IB145	5/8 - 11 Hex. Nut Sq.
33	VSB88	5/16 - 18 Hex. Hd. Cap Screw
34	IB10	5/16 - 18 Thumb Screw
35	IB139	3/8 - 16 Hex. Hd. Cap Screw
36	C249	5/16 - 18 Hex Nut

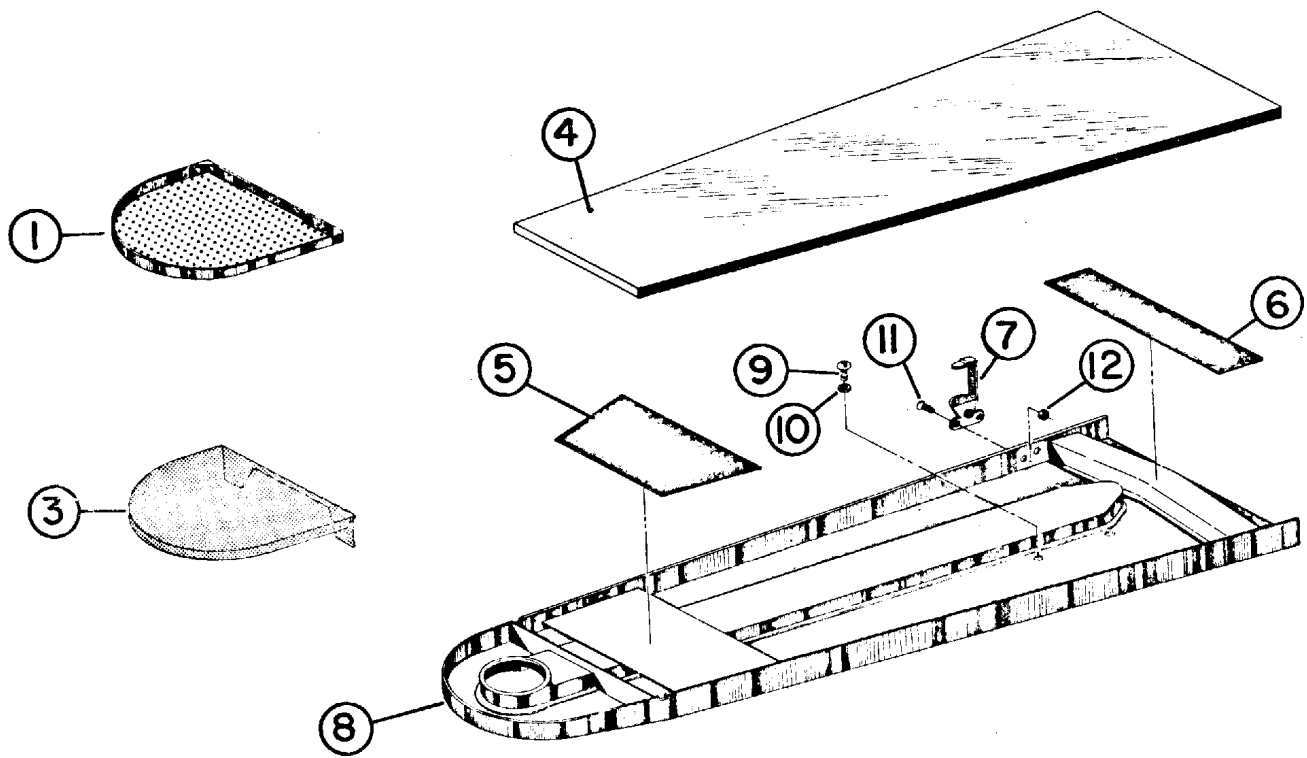

**VACUUM SPOTTING BOARD
MODEL "A"
LARGE PAN PARTS**

<u>Ref. No.</u>	<u>Part No.</u>	<u>Description</u>
1	VSB182	Spotting Nose w/Band & Spring
2		
3	VSB22	Large Perforated Nose
4	VSB204	Large White Glass w/Pads
5	VSB176	Front Pad Only
6	VSB173	Rear Pad Only
7	VSB15	Drip Cup Casting
8	VSB52	Large Pan Complete
9	VSB95	5/16 - 18 Rd. Hd. Screw
10	VSB171	5/16 Lead Washer
11	VSB155	1/4 - 20 Flat Hd. Screw
12	PT355	1/4 - 20 Hex. Nut

VSB65 - Large Pan Assembly includes
Part No's. 1,3,4,8, & Chemical Tray (VSB54)

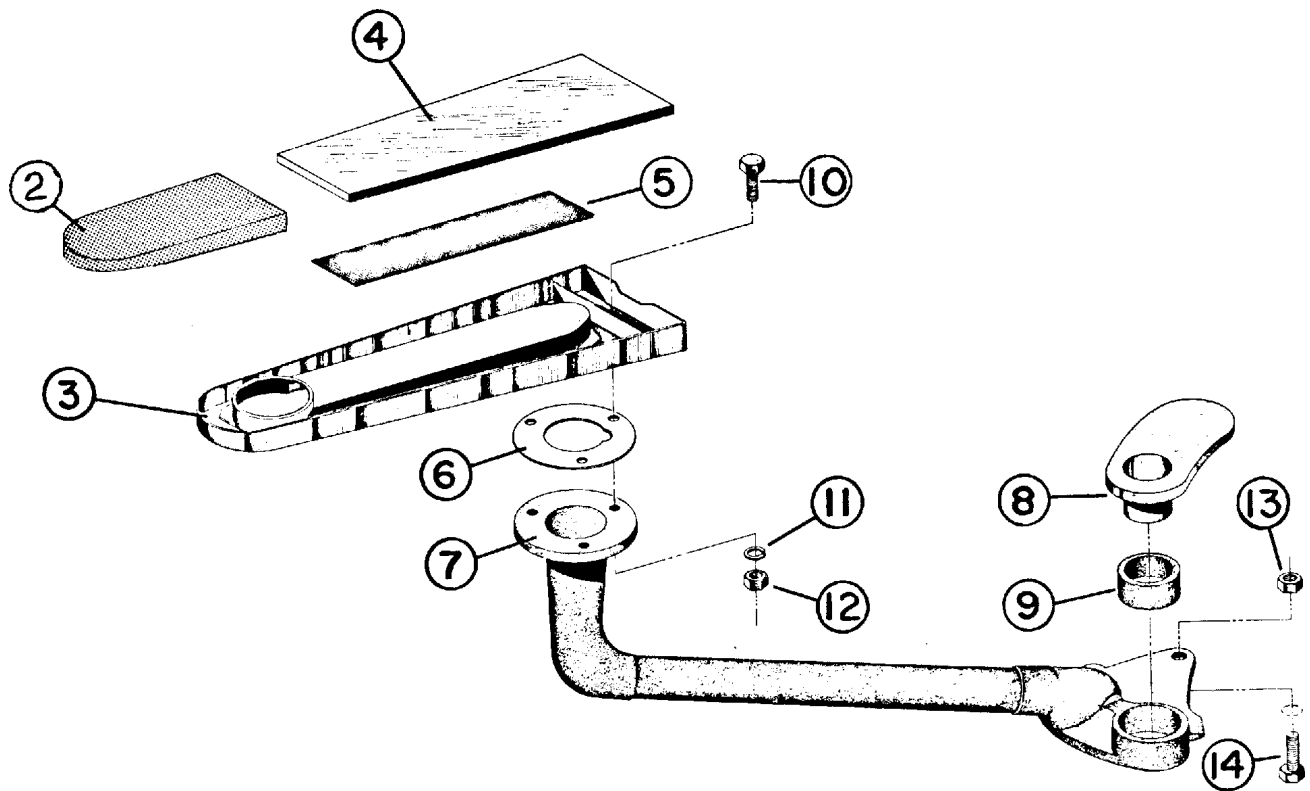

SWINGING SLEEVE BOARD

<u>Ref. No.</u>	<u>Part No.</u>	<u>Description</u>
1		
2	VSB188	Small Nose Asm.
3	VSB57	Sleeve Pan
4	VSB203	Small White Glass w/Pads
5	VSB173	Pad
6	VSB28	Gasket
7	VSB69	Elbow Slide Ass'y
8	VSB7	Upper Slide
9	VSB19	Rubber Sleeve
10	PT357	1/4 - 20 x 3/4" Hex. Hd. Screw
11	TU2846	1/4 - 20 Split Lockwasher
12	TU4934	1/4 - 20 Hex. Nut
13	VSB153	3/8 - 24 x 1" Hex. Hd. Cap Screw
14	VSB135	3/8 - 24 Hex. Nut

VSB60 - Swinging Sleeve Board Assembly includes all parts shown except Part No's. 8 & 9.

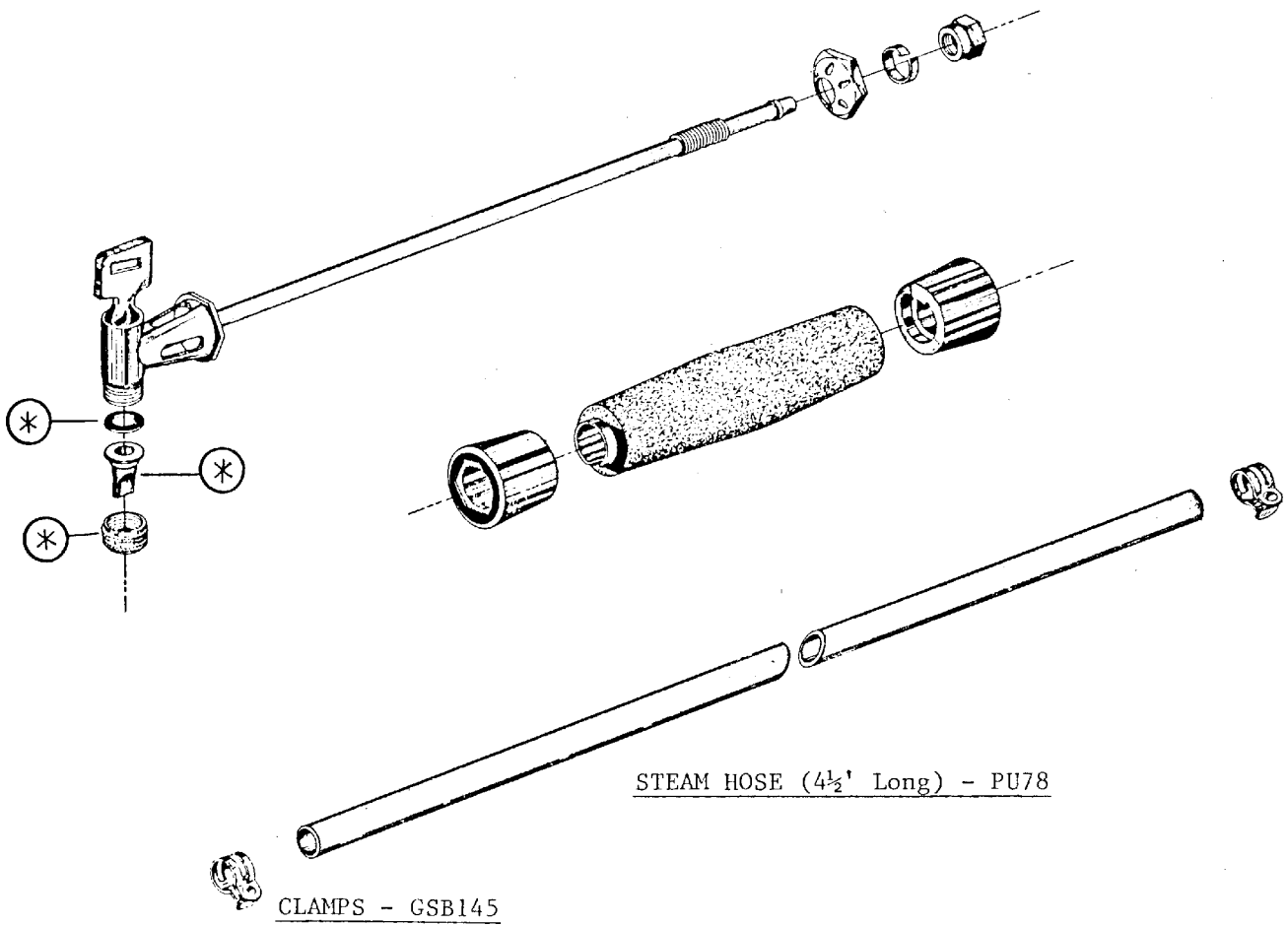

STEAM SPOTTING GUN & HOSE ASSEMBLY - SU68

STEAM SPOTTING GUN ONLY - SU49

REPAIR KIT - SKS49 - Includes parts to repair one spray gun. Parts in Kit marked (*).

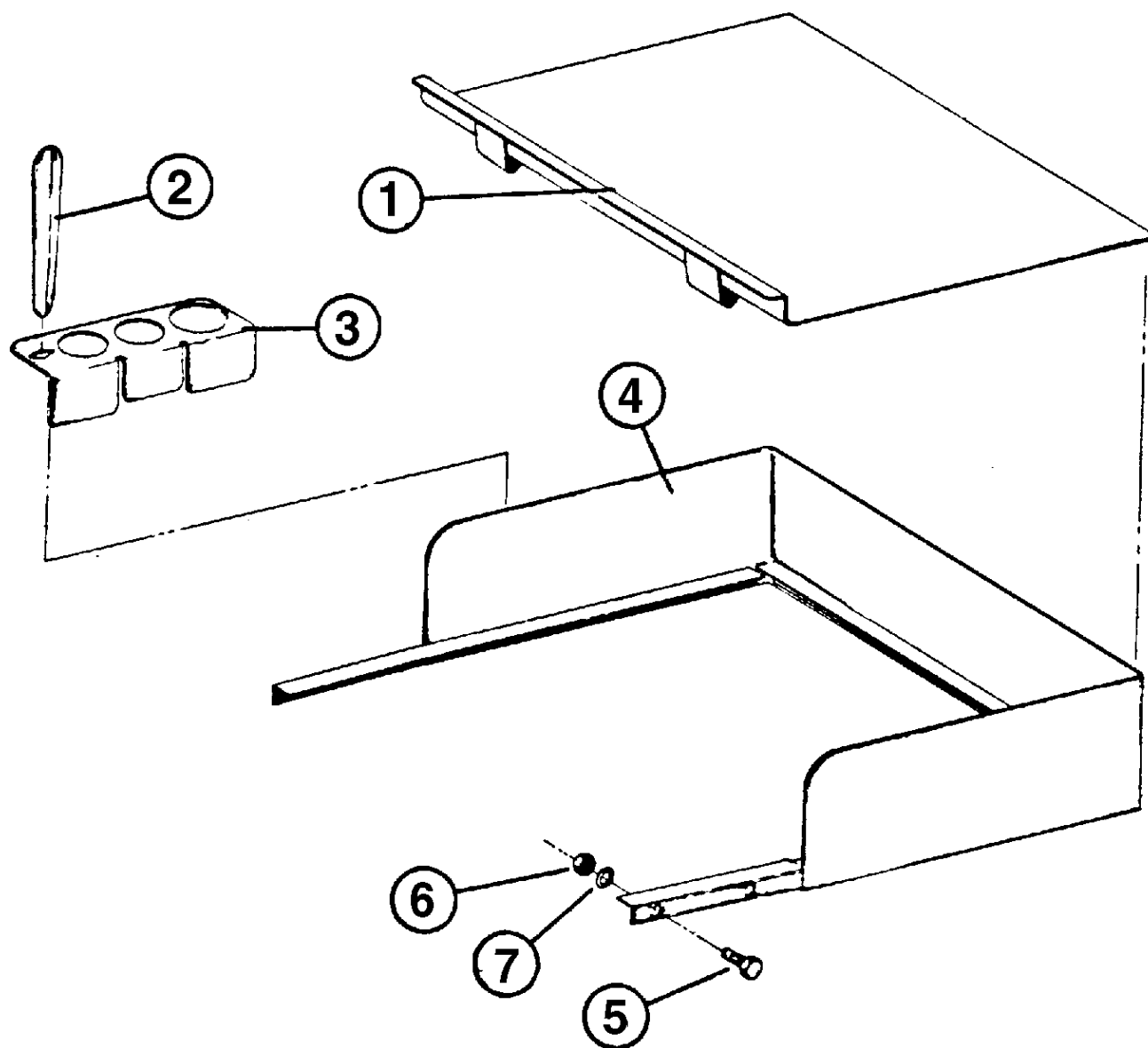

CHEMICAL SOLUTIONS TRAY PARTS

<u>Ref. No.</u>	<u>Part No.</u>	<u>Description</u>
1	VSB54	Solutions Tray
2	VSB45	Spatula
3	VSB44	Brush Holder
4	VSB53	Back Frame Assembly
5	PT357	1/4 - 20 x 3/4" Hex. Hd. Cap Screw
6	PT355	1/2 - 20 Hex. Nut
7	F860	1/4 Split Lock Washer

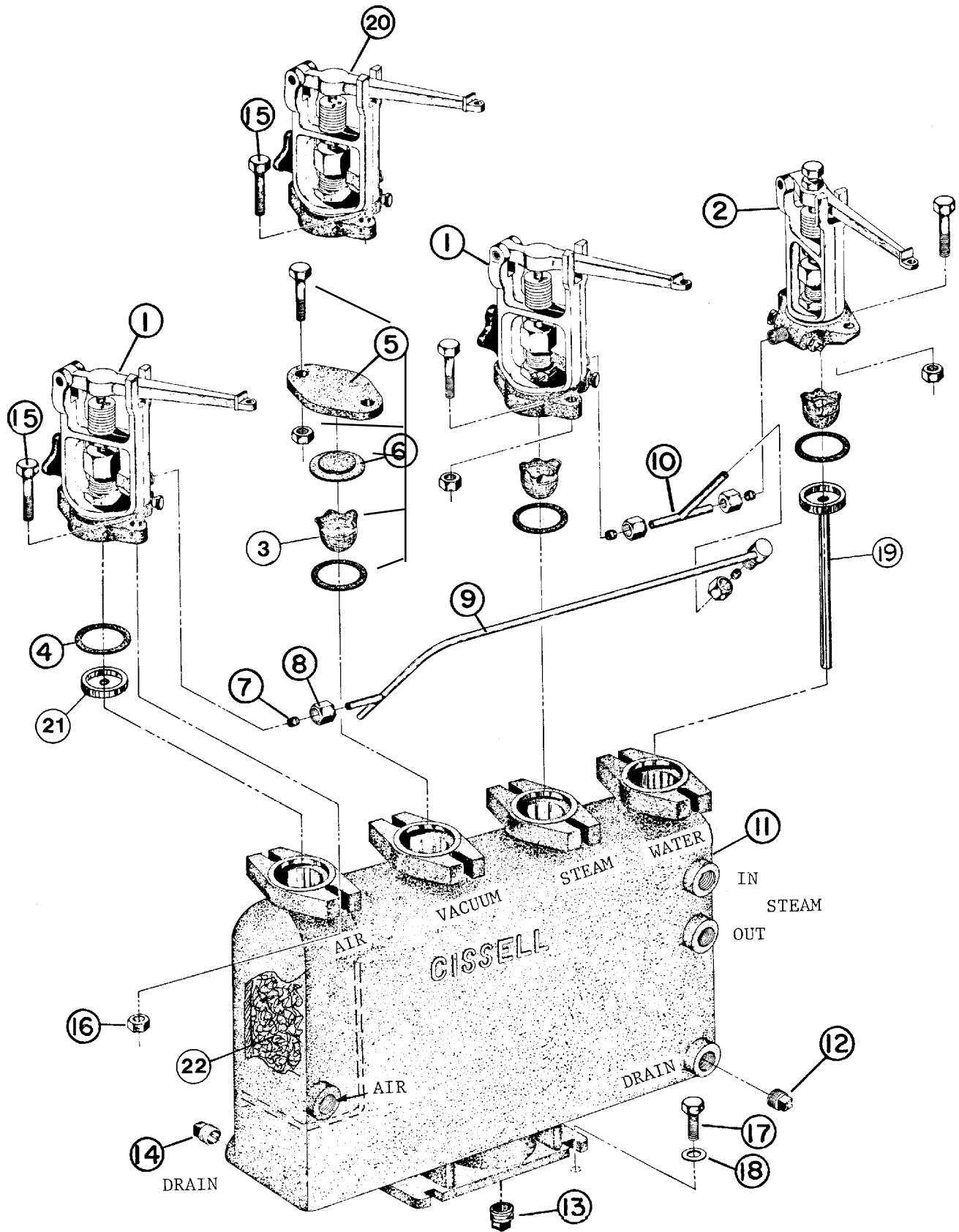

**STEAM CHAMBER & VALVE ASSEMBLY COMPLETE (AIR VACUUM) - VSB180
STEAM CHAMBER & VALVE ASSEMBLY COMPLETE (STEAM VACUUM) - VSB186**

<u>Ref. No.</u>	<u>Part No.</u>	<u>Description</u>
1	SU35H	Valve (Dry) (2 req'd.)
2	SU34H	Valve (Wet)
3	OP273	Strainer
4	V18K	Gasket (set of 6)
5	FB38	* Dummy Valve Assy.
7	PU8	1/4" Compression Bead
8	SU65	1/4" Compression Nut
9	VSB124	Triple Connector
10	SU26	Tee Connector
11	VSB400	** Steam Chamber Assembly (less valves)
12	J36	1/2" Pipe Plug
13	TU4612	3/4" Pipe Plug
14	P101	3/8" Pipe Plug
15	V51	5/16 - 24 Hex Hd. Cap Screw
16	V56	5/16 - 24 Hex Nut
17	FB189	1/4 - 20 x 1" Hex Hd. Cap Screw
18	TU2847	1/4" I.D. Cut Washer
19	SU62	Water Tube & Cup
20	VSB30	Head Valve (Steam Vacuum Only)
21	SU56	Cup
22	SB89	Copper Mesh
	VSB180	Steam Chamber & Valve Assembly Complete (Air Vacuum)
	VSB186	Steam Chamber & Valve Assembly Complete (Steam Vacuum)

* Used with air vacuum models only

** Consists of parts: 3, 4, 12, 13, 14, 19, chamber casting with copper filter and cup.

VSB62 Consists of 1, 2, 7, 8, 9, 10

VSB125 - Triple connection consists of: 7, 8, 9, 10

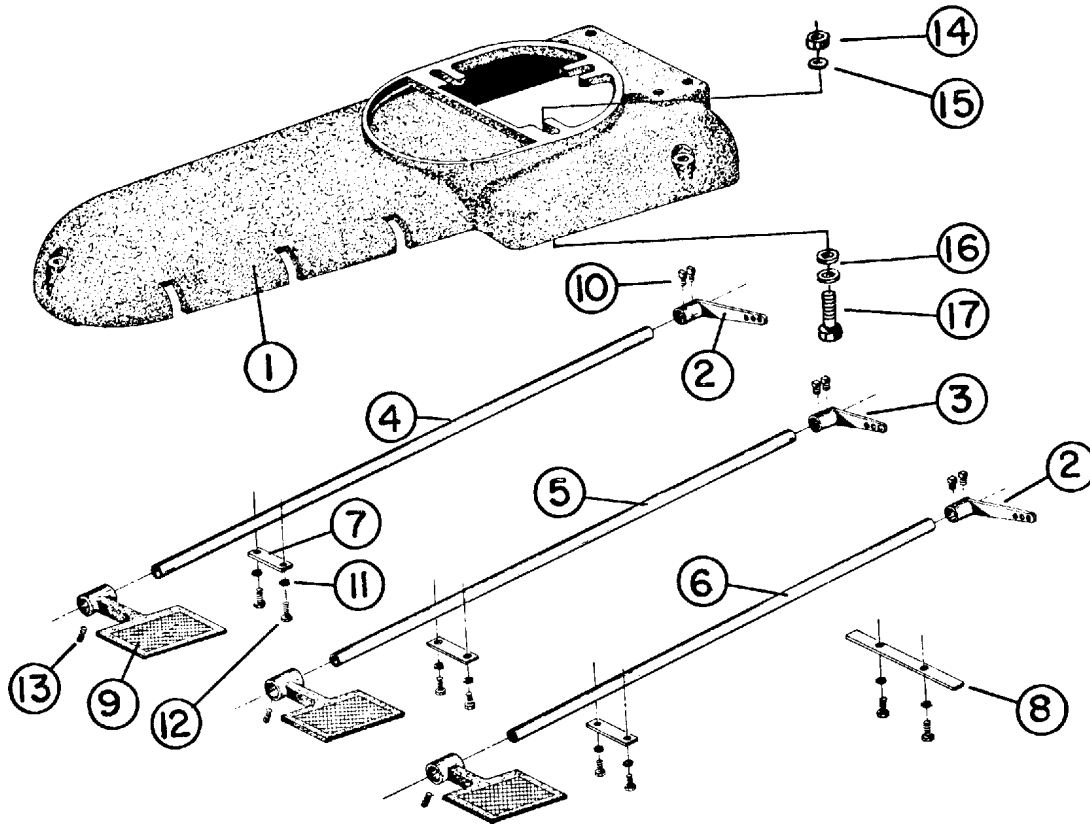

BASE ASSEMBLY

<u>Ref. No.</u>	<u>Part No.</u>	<u>Description</u>
1	VSB1	Base Casting
2	VSB3	Lever Ass'y. (2 req'd.)
3	FB3	Lever Ass'y.
4	VSB68	Pedal Rod 31"
5	VSB67	Pedal Rod 26"
6	VSB80	Pedal Rod 21"
7	VSB17	Strap (3 req'd.)
8	VSB79	Strap (1 req'd.)
9	FB2	Pedal (3 req'd.)
10	LB48	1/4 - 20 x 3/4" Sq. Hd. Set Screw
11	TU2846	1/4 Split Lock Washer
12	CB36	1/4 - 20 x 1/2" Hex. Hd. Cap Screw
13	J21	1/4 - 20 x 5/8" Sq. Hd. Set Screw
14	VSB135	3/8 - 24 Hex Nut
15	IB140	3/8 Cut Washer
16	VSB134	3/8 Lock Washer
17	VSB132	3/8 - 24 x 2 1/2" Hex. Bolt

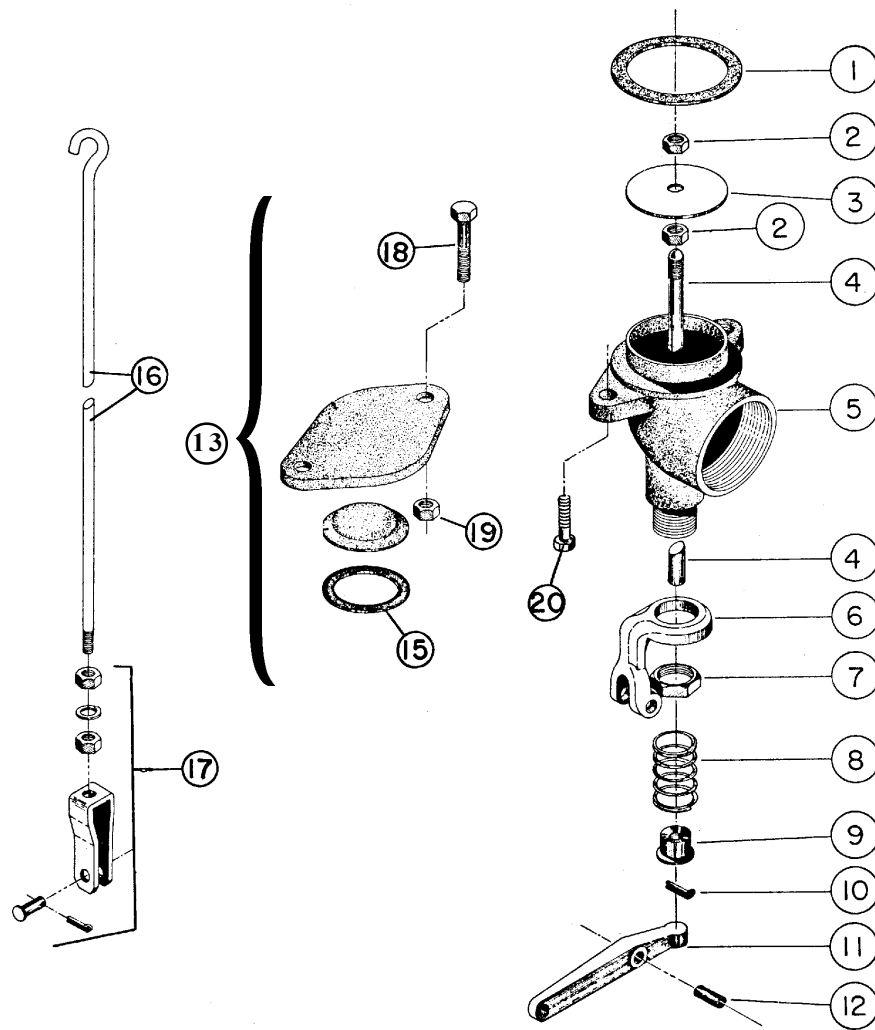

CENTRAL AIR VACUUM PARTS - VSB114

(VSB114 - Assembly does not include nos. 15, 18, 19)

<u>Ref. No.</u>	<u>Part No.</u>	<u>Description</u>	<u>Ref. No.</u>	<u>Part No.</u>	<u>Description</u>
1	FB32	Gasket	11	FB15	Lever
2	V15	Small Lock Nut	12	VSB128	Roll Pin
3	FB16	Disc	13	FB381	Dummy Valve Assy.
4	VA4	Valve Stem	15	V18	Gasket
5	FB229	Air Vacuum Body	16	FB931	Pedal Rod
6	SF15	Fork	17	SF49	Yoke Ass'y.
7	OP547	Large Lock Nut	18	V51	5/16 - 24 Hx. Hd. Cap Screw
8	V345	Spring (45 Lb.)	19	V56	5/16 - 24 Hex Nut
9	V12	Gland	20	FB124	5/16 - 18 Hex. Hd Cap Screw
10	V2	Cottor Pin			

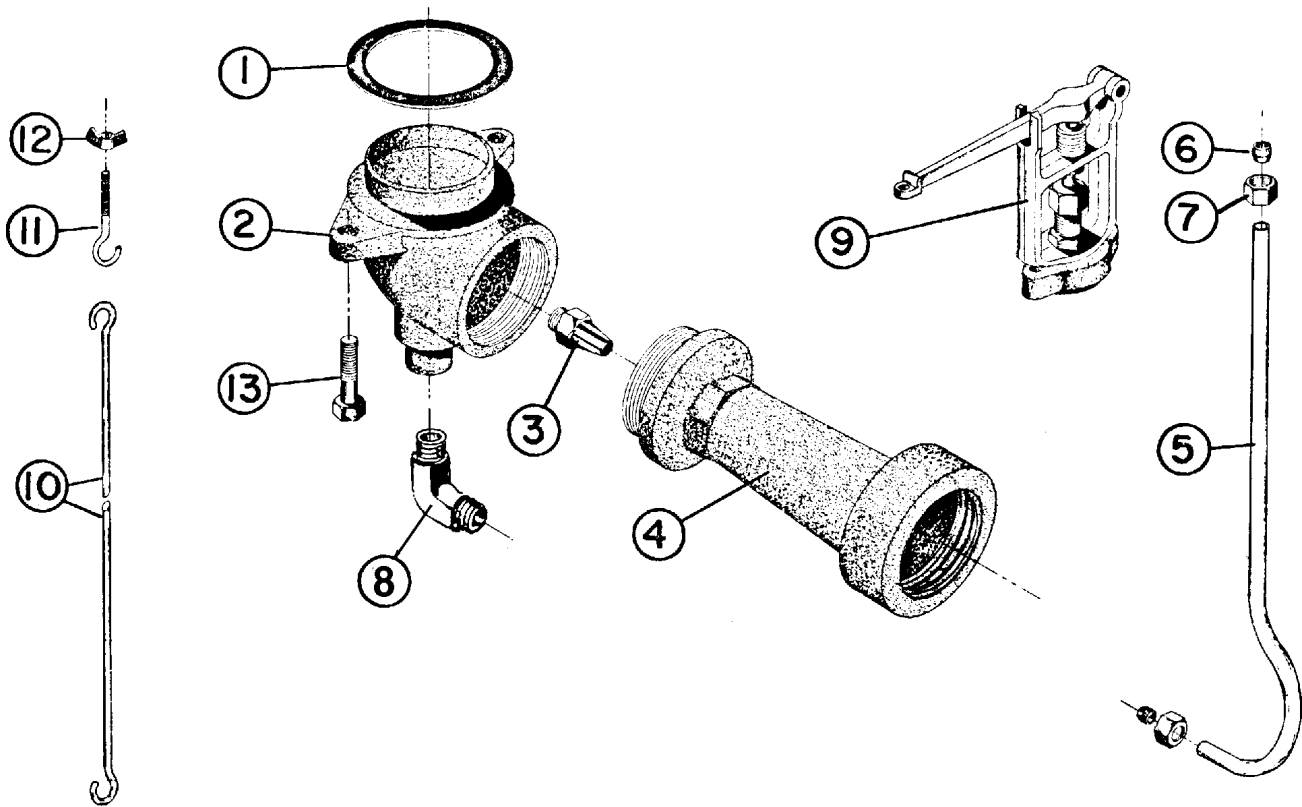

VSB-115 - STEAM VACUUM PARTS - CONSISTS OF PARTS 1-13

**FB80 STEAM VACUUM VALVE W/VENTURI
CONSISTS OF PARTS REF. NOS. 1, 2, 3, 4, 8, 13**

<u>Ref. No.</u>	<u>Part No.</u>	<u>Description</u>
1	FB32	Gasket
2	FB9	Steam Vacuum Body
3	FB12	Orifice
4	FB11	Venturi
5	VSB29	3/8" Copper Tubing
6	SF117	3/8" Compression Bead
7	SF120	3/8" Compression Nut
8	SF46	1/4" MPT x 3/8" Tube Elbow
9	VSB30	Steam Vacuum Valve
10	VSB31	16" Pedal Rod
11	J10	3/16 - 3 Eye Bolt
12	VSB154	#10 - 24 Wing Nut
13	FB124	5/16 - 18 Hex Hd. Cap Screw

CISSELL HEAD VALVES

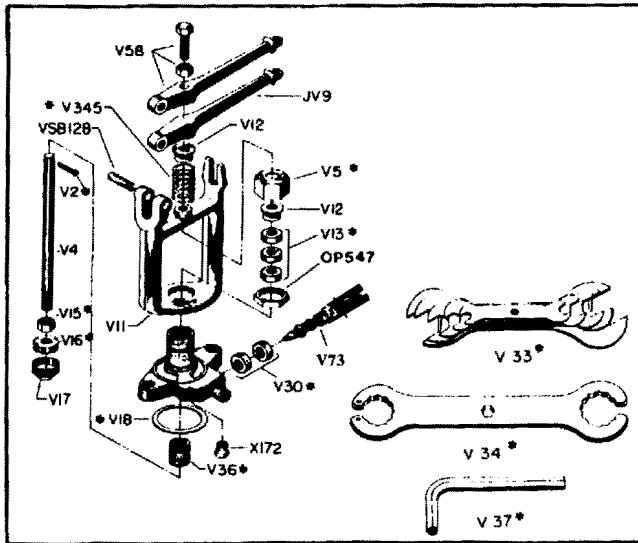

OP547	Large Lock Nut	V58	Lever (Wet)
V73	Control Knob	VSB128	Roll Pin
JV9	Lever (Air or Dry)	V04	Stem
V11	Fork	V62	Valve Body
V12	Gland	X172	Core Plug
V17	Disc Holder		

SKL74 - Valve Service Kit* Plastic box containing these parts & qty. -

V33	Set of 5 wrenches -1	V345	Spring -3
V34	12 point valve wrench -1	V37	Hex wrench -1
V36	Valve seat -1	V35	Stem & disc holder -3
V13	Large Pack Rings -12	V18	Gasket -4
V30	Small Pack Rings -12	V5	Large pack nut -1

* V 35 Stem & Disc Holder
Assembly for all
Head Valves except
SFC 54 and GFV 77
(Includes V 16 Teflon Disc)



HOW TO SERVICE CISSELL VALVES

LEAK AT LARGE PACK NUT. Tighten large pack nut (Photo 1) but retain free movement of stem. New packing will allow several adjustments before replacement is required. Should packing leak after adjustment, add a V 13 Pack Ring which is split to permit easy installation without removing stem. After use, the old style packing becomes hard and brittle, causing valve stem to bind when pack nut is tightened. Remove hard packing and replace with three new V 13 Split Pack Ring.

LEAK AT STEAM CONTROL KNOB. Tighten small pack nut. If leak continues, remove old packing and replace with two new V 30 pack rings.

VALVE WON'T CUT OFF. Replace old disc if it is cracked or pitted preventing a perfect seat. Replace weak valve spring. If spring and disc are satisfactory, seat in valve body may be damaged or valve stem bent. Defective parts must be replaced to secure proper operation. When major repairs are required, install a Cissell Replacement Valve.

TO REPLACE DISC. Exhaust steam from chamber, then remove valve. Pull cotter pin from Valve stem using end of Cissell V 34 12-point Wrench (Photo 2). Remove disc holder assembly and dis-assemble (Photo 3). Replace old disc with V 16 Teflon Disc and retighten disc lock nut.

WHEN VALVE IS REMOVED FROM CHAMBER always clean old gasket from valve and chamber and replace with new V 18 gasket. When re-installing valve on chamber, tighten bolts equally. If valve does not clamp gasket evenly, steam will escape around gasket. After chamber is heated by steam, re-tighten bolts to prevent blowing of gasket.

LOOSE FORK. Position Fork and tighten large Lock Nut (Photo 4). Tap Fork with hammer to help tighten as wrench tightens large Lock Nut.

REPLACING VALVES. Blow all loose scale and dirt from within valves before installing; as a small particle of dirt or scale may prevent proper operation of valve, by becoming lodged between seat and disc, or closing off orifice.

The V 13 SPLIT PACKING RING is similar in appearance to parts previously used in Cissell Head Valves; but actually is compounded to give you better and longer performance.

The V 13 SPLIT PACKING RING is now made of a Teflon composition that will not harden.

The V 30 SPLIT PACKING RING is also made of a Teflon composition that will not harden.

This new feature greatly increases the service from your Cissell Head Valves.

The Cissell Valve Wrench does four important jobs

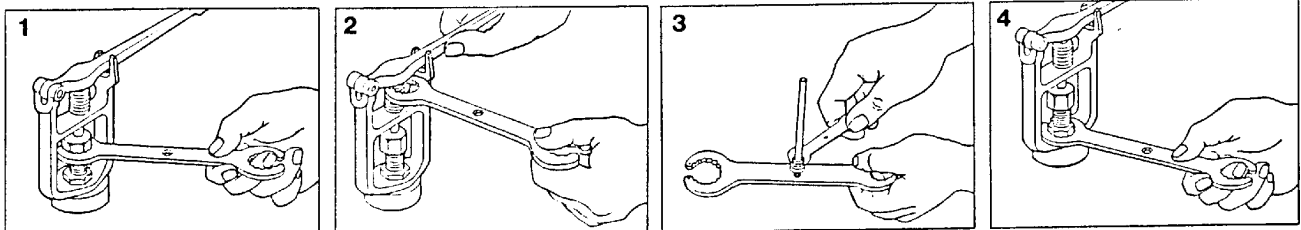

TROUBLE - SHOOTING

PROBLEM	CAUSE	REMEDY
(1) No steam	Steam supply valve off	Open gate valve in steam supply line.
	Valve is not operating	Check operation of valve (2) Replace valve seat per installation on page 20.
(2) Steam valve does not operate	Check foot pedal movement	Tighten set screws if no movement.
	Check valve rod movement	Tighten rod yoke if no movement.
(3) Steam leaks continuously through spotting gun	Check foot pedal movements	Pedals hung up, loosen.
	Steam valve loose	Tighten collar nut.
(4) Water drips from spotting gun	Wet steam	Trap is malfunctioning, replace or clean out.
	See Item (3)	
(5) Wet steam	Trap not operating	Replace or clean out.
	Return line shut off	Open gate valve in return line.
	No risers installed in steam supply and return line	Install risers as specified in installation sheet.
	Heavy condensate in supply header Check foot pedal movement	Install a by-pass trap in supply line prior to board.
	Valve is not operating	Check "C", page 8.
(6) Steam does not shut off	Check foot pedal movement	Check operation (2)
	Check foot pedal movement	Check "C", page 8.
(7) Vacuum does not work	Check valve rod movement	Tighten set screws if no movement.
	Check central air vacuum unit	Tighten loose yoke if no movement.
	If equipped with steam vacuum	Turn it on if not operating.
	Check supply air valve	Check valve per instruction on page 20.
(8) No air	Check foot pedal movement	Open air gate valve.
	Check air valve rod movement	Tighten set screws if no movement.
	Valve is not operating	Tighten loose yoke if no movement.
		Replace valve seat.

